

UPE-3 and UPE-6 Enclosures

Technical Manual

Effective: June 2014



Safety Notes

Alpha considers customer safety and satisfaction its most important priority. To reduce the risk of injury or death and to ensure continual safe operation of this product, certain information is presented differently in this manual. Alpha encourages special attention and care to information presented in this manner.



WARNING! GENERAL HAZARD

WARNING provides safety information to reduce the risk of INJURY OR DEATH to the technician or user.



WARNING! ELECTRICAL HAZARD

ELECTRICAL HAZARD WARNING provides electrical safety information to PREVENT INJURY OR DEATH to the technician or user.



WARNING! FUMES HAZARD

FUMES HAZARD WARNING provides fumes safety information to PREVENT INJURY OR DEATH to the technician or user.



WARNING! FIRE HAZARD

FIRE HAZARD WARNING provides fumes safety information to PREVENT INJURY OR DEATH to the technician or user.

There may be multiple warning associated with the callout. Example:



WARNING! FIRE HAZARD

This WARNING provides safety information for both Electrical AND Fire Hazards.



CAUTION!

CAUTION provides safety information intended to PREVENT DAMAGE to material or equipment.



NOTICE:

NOTICE provides additional information to help complete a specific task or procedure.

ATTENTION

ATTENTION provides specific regulatory/code requirements that may affect the placement of equipment and/or installation procedures.

UPE-3 and UPE-6 Technical Manual

031-124-C0-004, Rev. D1

Effective Date: June, 2014

Copyright© 2014

Alpha Technologies, Inc.

member of The  Group™

 **NOTICE:**

Photographs contained in this manual are for illustrative purposes only. These photographs may not match your installation.

 **NOTICE:**

Operator is cautioned to review the drawings and illustrations contained in this manual before proceeding. If there are questions regarding the safe operation of this powering system, please contact Alpha Technologies or your nearest Alpha representative.

 **NOTICE:**

Alpha shall not be held liable for any damage or injury involving its enclosures, power supplies, generators, batteries, or other hardware if used or operated in any manner or subject to any condition not consistent with its intended purpose, or is installed or operated in an unapproved manner, or improperly maintained.

To contact Alpha Technologies:

Visit *www.alpha.com*

or

For general product information and customer service (7 AM to 5 PM, Pacific Time), call

1-800-863-3930,

For complete technical support, call

1-800-863-3364

7 AM to 5 PM, Pacific Time or 24/7 emergency support

To report errors and/or omissions in this document, send an email to:

Techpubs@alpha.com

Table of Contents

Safety Notes	6
1.0 Introduction	8
1.1 Enclosure Dimensions	9
1.2 Precast Pad and Pedestal Mounting Options	10
1.3 Pour-In-Place Concrete Pad Installation.....	12
2.0 Installation.....	13
2.1 Site Considerations.....	13
2.2 Transportation and Lifting	13
2.3 Enclosure Installation.....	14
2.4 Attaching the External Coax Raceway.....	15
2.5 Enclosure Grounding	16
2.6 Utility Power Connection.....	17
2.7 Coaxial Cable Connection	22
2.8 Power Supply Placement.....	23
2.9 Battery Installation	23
2.9.1 Battery Date Code Usage and Identification.....	23
2.9.2 Battery Installation Procedure	24
2.9.3 Battery Terminal Connections	25
2.9.4 Connecting the Battery Integration Tray.....	27
2.9.5 Battery Wiring Diagrams (UPE with Slide Tray).....	29
2.10 Enclosure Protection.....	31
3.0 Enclosure Options	32
3.1 Battery Remote Temperature Sensor (RTS).....	32
3.2 Lightning and Surge Arrester Options.....	33
3.3 Battery Heater Mat.....	34
3.4 LRI-ACI Lamp Option.....	34
3.5 Enclosure Door Tamper Switch and Cooling Fan Options.....	35

List of Figures

Fig. 1-1, UPE-3 Enclosure.....	8
Fig. 1-2, Layout for Precast Pad.....	10
Fig. 1-3, PS-6 Standard Pedestal (UPE-3 only)	11
Fig. 1-4, PS-6XL Pedestal (UPE-3 and UPE-6)	11
Fig. 1-5, Typical Site Arrangement for Pedestal and Cover.....	11
Fig. 1-6, Pour-In-Place Concrete Pad Installation.....	12
Fig. 2-1, External Coax Raceway	15
Fig. 2-2, Typical Service Entrance Wiring.....	19
Fig. 2-3, Breaker-Quad-Option Wiring and Circuit Breaker Part Numbers	20
Fig. 2-4, 120/240Vac UL Wiring	21
Fig. 2-5, Battery Date Code.....	23
Fig. 2-6 Threaded Insert Battery Terminal Connections	25
Fig. 2-7, Flag Battery Terminal Connections	26
Fig. 2-8, Battery Integration Tray Connections	27
Fig. 2-9, UPE-3 Battery Wiring Diagram (for use with slide tray)	28
Fig. 2-10 UPE-6 Battery Wiring Diagram (for use with slide tray)	29
Fig. 2-11, Bollard Placement	30
Fig. 3-1, RTS Placement	32
Fig. 3-2, LAP Plus.....	33
Fig. 3-3, ISA-120/240 Secondary Surge Arrester	33
Fig. 3-4, ACI/LRI Wiring.....	34
Fig. 3-5, Tamper Switch Placement.....	35
Fig. 3-6, Cooling Fan Placement.....	35

UPE-3 and UPE-6 Safety Notes

Review the drawings and illustrations contained in this manual before proceeding. If there are any questions regarding the safe installation or operation of this product, contact Alpha Technologies or the nearest Alpha representative. Save this document for future reference.

To reduce the risk of injury or death and to ensure the continued safe operation of this product, the following symbols have been placed throughout this manual. Where these symbols appear, use extra care and attention.



WARNING! GENERAL HAZARD

- Only authorized and trained personnel should maintain or service the enclosure.
- Always lock the enclosure after servicing.
- Read and follow all installation, equipment grounding, usage, and service instructions for this product and products used in conjunction with it.
- Servicing and connection of batteries shall be performed by, or under the direct supervision of, personnel knowledgeable of batteries and the required safety precautions.
- Use proper lifting techniques whenever handling enclosure, equipment, parts, or batteries.
- If any battery emission contacts the skin, wash immediately and thoroughly with water. Follow your company's approved chemical exposure procedures.
- Neutralize any spilled battery emission with the special solution contained in an approved spill kit or with a solution of one pound Bicarbonate of soda to one gallon of water. Report chemical spill using your company's spill reporting structure and seek medical attention if necessary.
- Use caution around sheet metal components and sharp edges.



WARNING! ELECTRICAL HAZARD

- Removal all conductive jewelry or personal equipment prior to servicing equipment, parts, connectors, wiring, or batteries.
- Batteries contain dangerous voltage and corrosive material. Only authorized and trained personnel should install, maintain, or service the batteries.
- Always use insulated tools to install, maintain, or service batteries.
- Use special caution when connecting or adjusting battery cabling. An improperly connected battery cable or an unconnected battery cable can result in arcing, fire, or possible explosion.



WARNING! FUMES HAZARD

- Avoid any contact with gelled or liquid emissions from valve-regulated lead-acid (VRLA) batteries. Emissions contain dilute sulfuric acid that is harmful to the skin and eyes. Emissions are electrolytic, and are electrically conductive and are corrosive. Follow the Chemical Hazards notes if contact occurs.
- All battery compartments must have adequate ventilation to prevent an accumulation of potentially dangerous gas.

- Batteries contain or emit chemicals known to the State of California to cause cancer and birth defects or other reproductive harm. Battery post terminals and related accessories contain lead and lead compounds. Wash hands after handling (California Proposition 65).



WARNING! FIRE HAZARD

- Batteries produce explosive gases. Do not smoke or introduce sparks in the vicinity of batteries.
- Power supplies can reach extreme temperature under load.



CAUTION!

- Always verify that ALL equipment is rated for both the input and output voltages of the current application and is in proper working condition.
- To prevent damage, inspect batteries every 3 months

ATTENTION

- Prior to installation, contact local utilities, building maintenance departments, and cable/piping locator services to ensure that installation does not interfere with existing utility cables or piping
- Installer must check local codes regarding the placement of equipment with flammable material installed on utility equipment.
- Spent or damaged batteries are considered environmentally unsafe. Always recycle used batteries or dispose of the batteries in accordance with all federal, state and local regulations.

1.0 Introduction

UPE Series enclosures support distributed powering architectures in broadband applications. The power supply is located on the equipment shelf above the batteries for maximum convection cooling. Ideal for use in all climates, each enclosure comes with a removable, lockable door. Standard features include battery slide trays, high magnetic circuit breaker, duplex AC receptacle, service power inserter (SPI) and external coax raceway.

Key Features:

- Engineered to accommodate broadband powering applications in ground-mount configurations
- Battery Integration Tray or sliding battery trays with lock-in/lock-out features
- Internal or external SUSE-rated service entrance options available
- Enclosures are agency certified for applicable industry standards
- Welded aluminum construction and powdercoat finish provides superior corrosion resistance
- Portable generator cabling access door



Fig. 1-1, UPE-3 Enclosure

1.0 Introduction, continued

1.1 Enclosure Dimensions

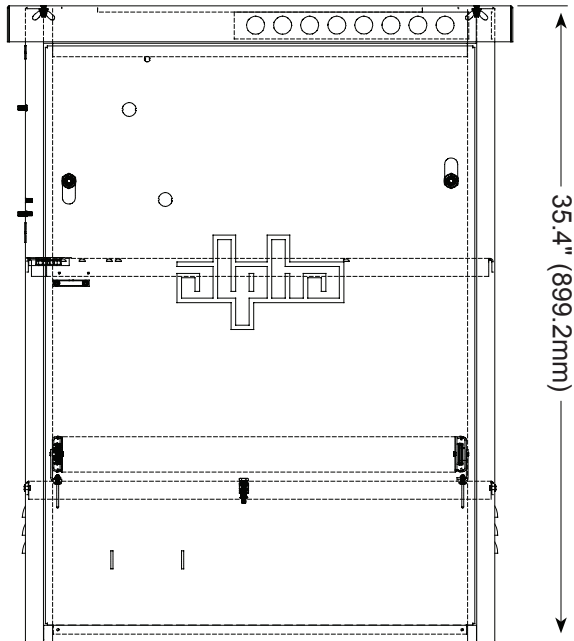
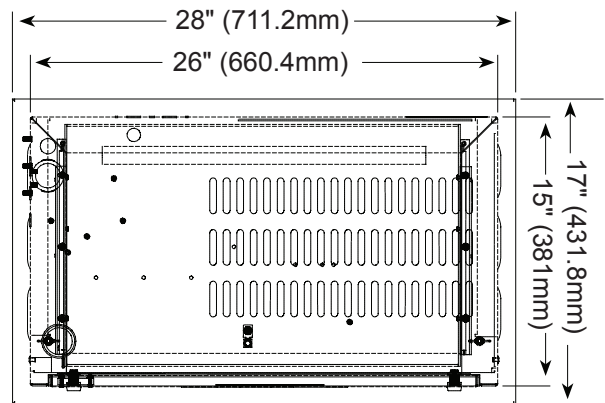
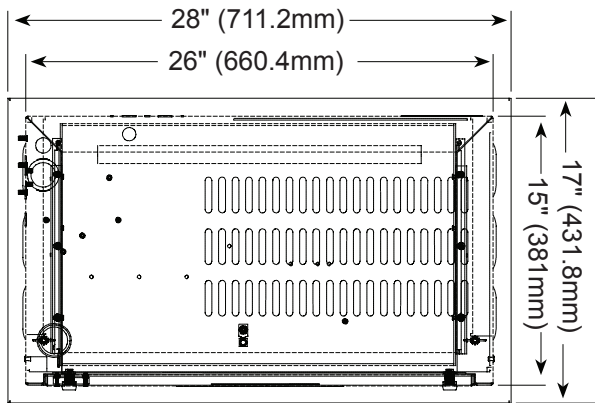

UPE-3

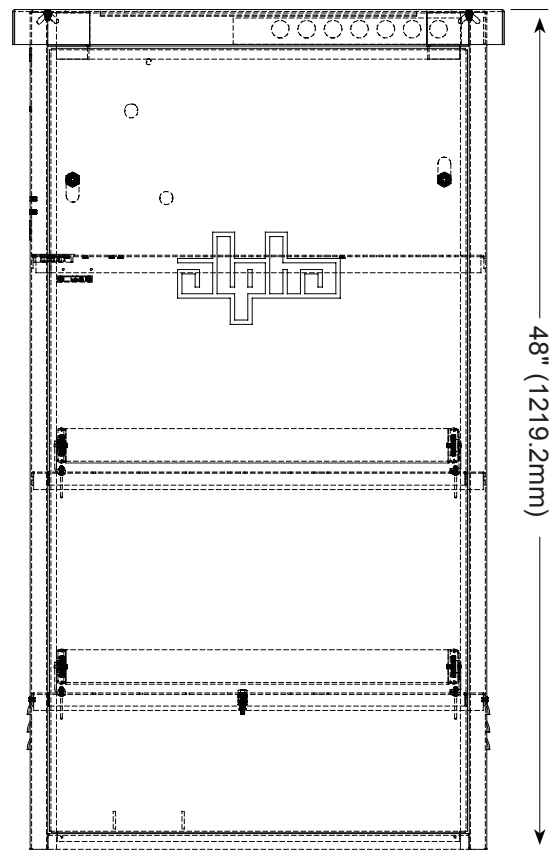

UPE-6

1.0 Introduction, continued

1.2 Precast Pad and Pedestal Mounting Options

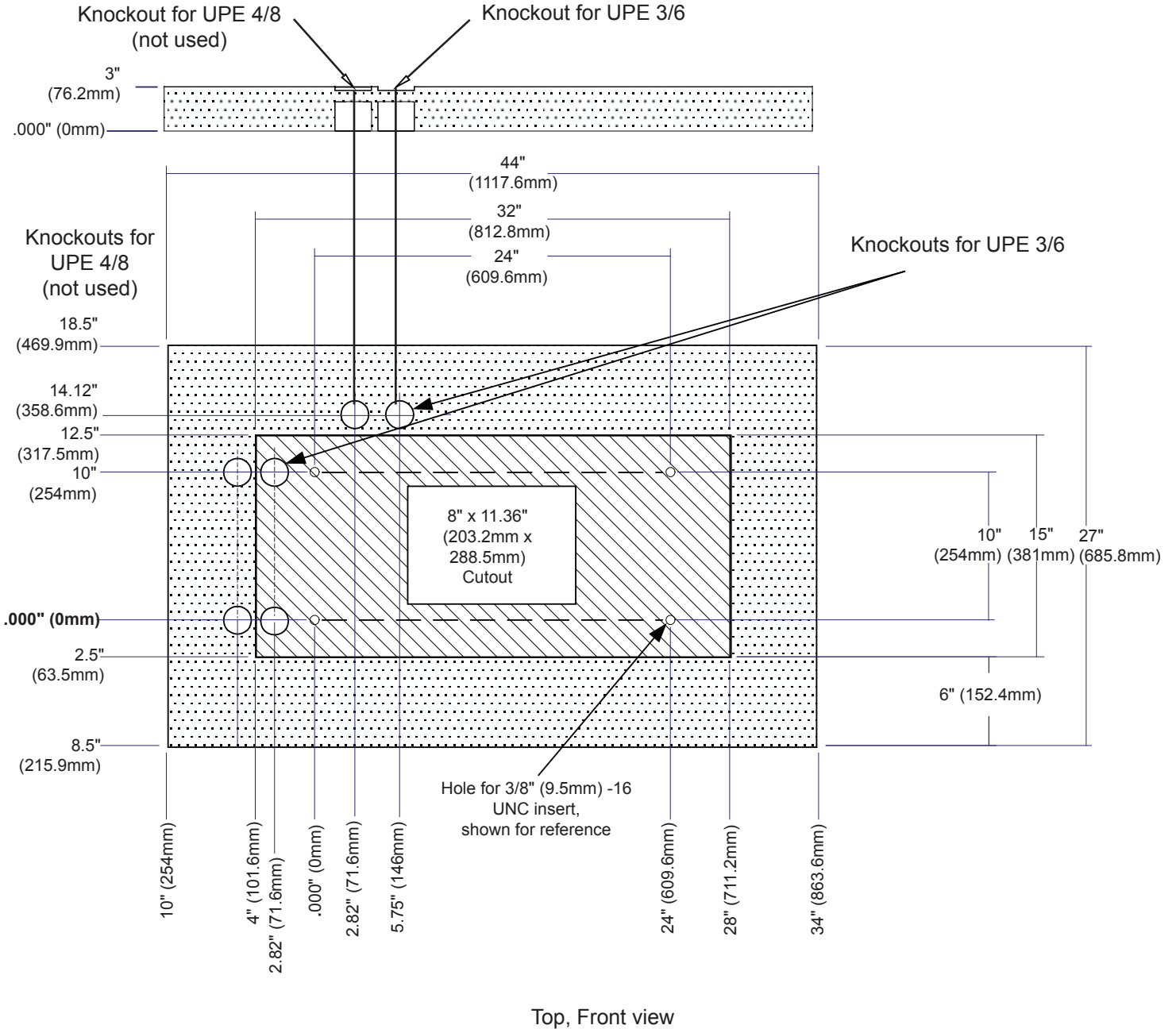

Fig. 1-2, Layout for Precast Pad, Single-wide for UPE-3 and -6
Alpha P/N 641-112-10

1.0 Introduction, continued

1.2 Precast Pad and Pedestal Mounting Options, continued

Alpha's precast pedestal support system provides a quick, one-step solution for installing UPE Series enclosures. Contact Alpha Technologies Customer Service (1-800-863-3930) to determine which pedestal support is needed for your installation. Alpha recommends using the larger base, PS-6XL, for the UPE-6.

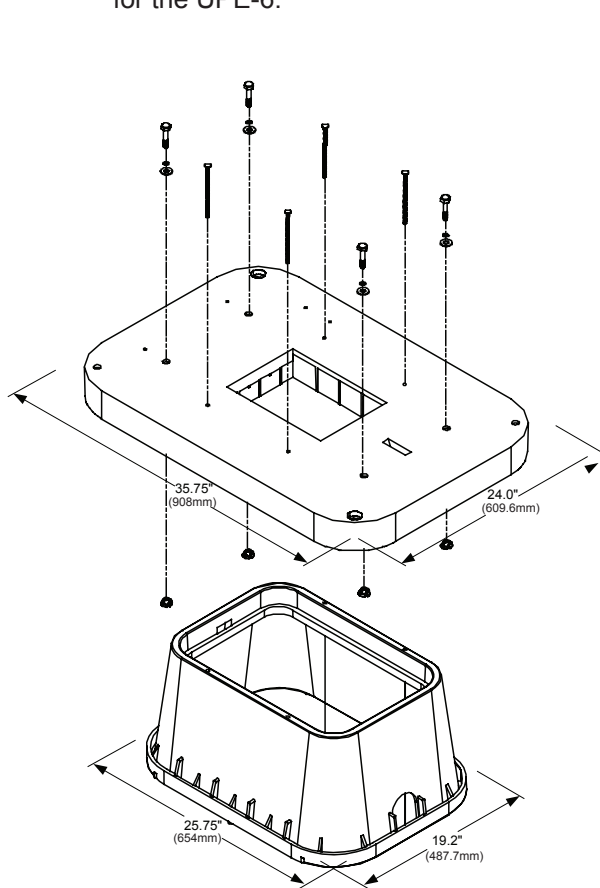

Fig. 1-3, PS-6 Standard Pedestal (UPE-3 only)
Alpha P/N 745-324-20

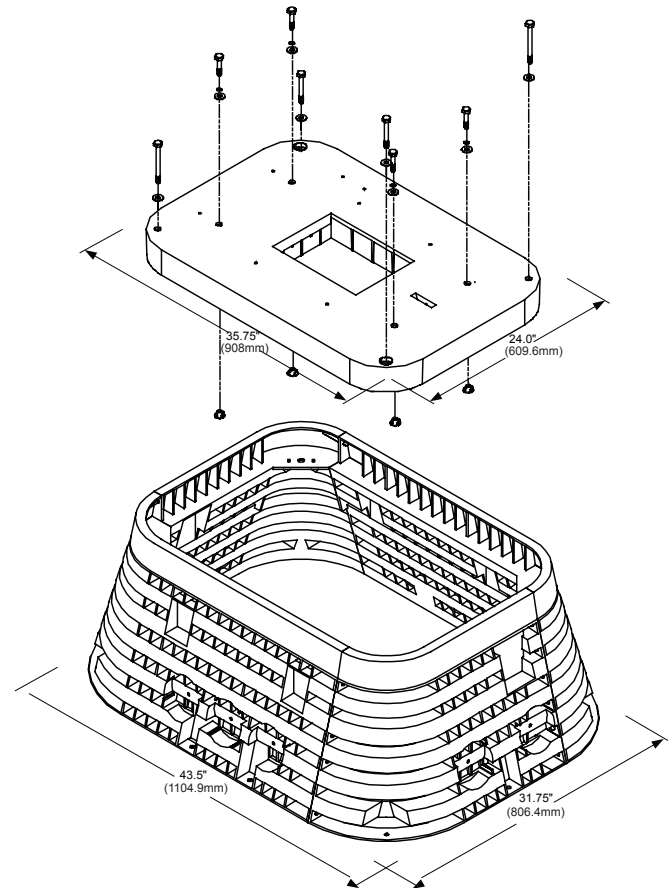

Fig. 1-4, PS-6XL Pedestal (UPE-3 and UPE-6)
Alpha P/N 745-324-21

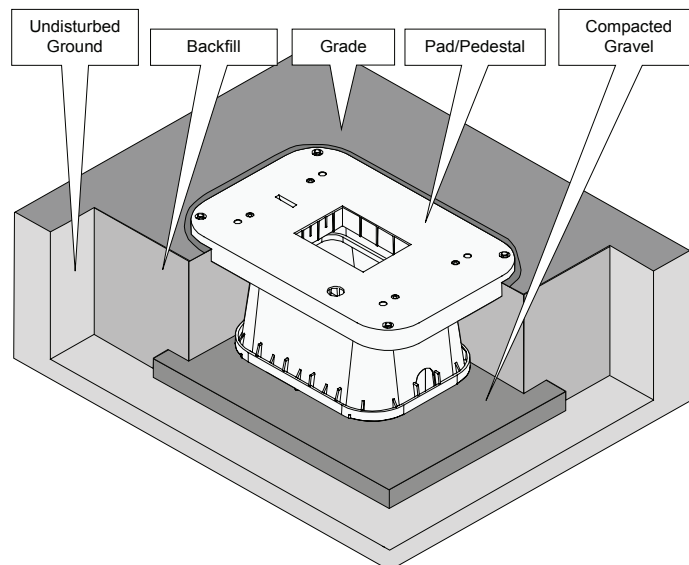

Fig. 1-5, Typical Site Arrangement for Pedestal and Cover

1.0 Introduction, continued

1.3 Pour-In-Place Concrete Pad Installation

Hardware Recommendations:

- 7/16" Nut
- Lock Washer
- Flat Washer
- Concrete Pad with 7/16" Mounting Studs

Installation Instructions:

1. Consult local codes for concrete pad requirements.
2. The UPE enclosure must be bolted down to a completely flat surface. If the concrete pad is uneven or has bumps, cracks, or other imperfections, the installer is responsible for correcting these defects prior to installing the enclosure. Alpha technologies is not responsible for damage to the enclosure caused by improper installation.
3. Proper soil compaction is required to prevent settling of the pad.
4. Additional pad clearance may be desirable to reduce debris build up around the enclosure.
5. Steel reinforcement bars or mesh may be used to reduce cracking and resettling due to changes in humidity and temperature.

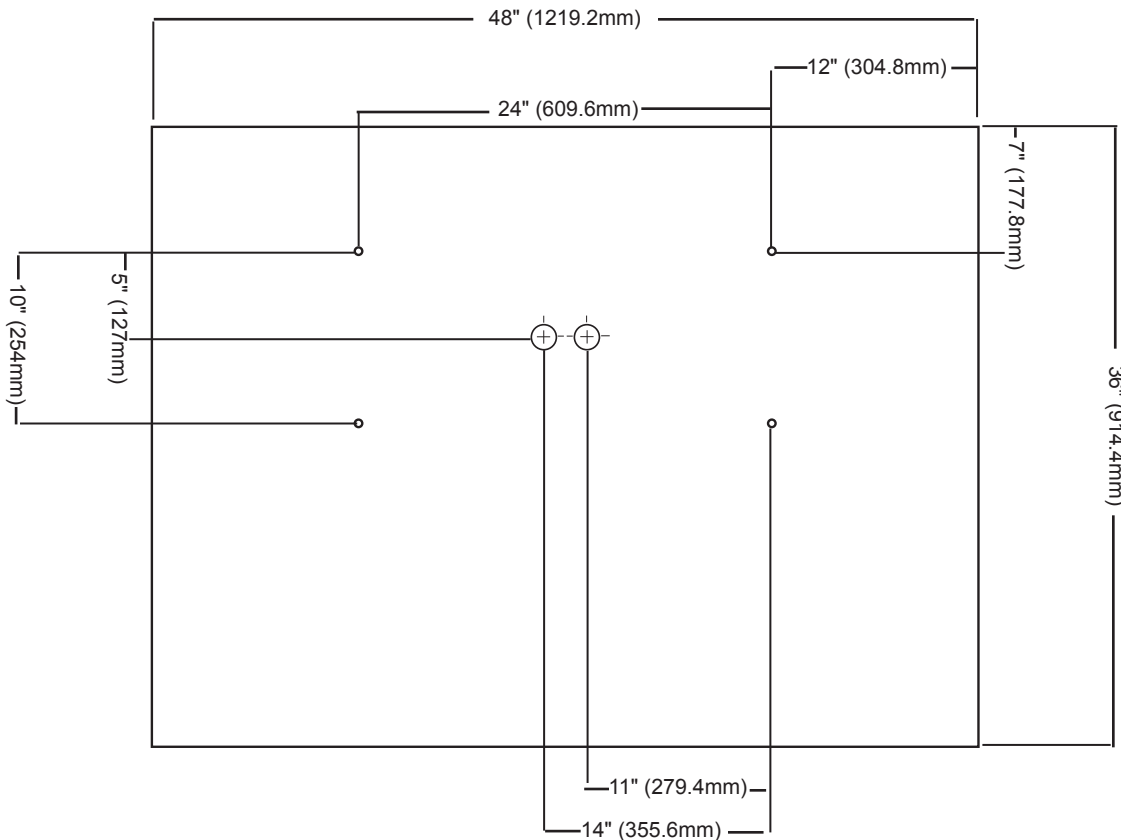

Fig. 1-6, Pour-In-Place Concrete Pad Installation

2.0 Installation

2.1 Site Considerations

- The site must be planned so the enclosure receives good air flow. If possible, in areas of extreme heat, it is best to position the enclosure so that it will be shaded from the afternoon sun. If no shade is available, a factory installed fan kit is highly recommended. In areas of prevailing winds, it is best that the enclosure be located so that the sides of the cabinet face the winds instead of the doors. This will greatly reduce the buildup of sand or snow against the enclosure's air vents.
- In areas of potential flooding, the site must be located above the 100-year flood plain.
- The enclosure must be placed where it will be free of obstructions, allowing easy access to the doors for service or equipment access. For ventilation and maintenance, allow a minimum space of 36" (914.4mm) in front, and 36" (914.4mm) in the rear between the enclosure and other solid structures.
- Place the enclosure well away from sources of forced water, such as underground sprinkler systems and direct roadway splash.
- The concrete pad drawing provided in this manual contains all of the required mounting details, including electrical service and cable plant entrances.
- For ease of installation, lightweight polymer concrete pads are available from Alpha Technologies for all UPE series enclosures.
- The vapor barrier material (such as 30 lb. felt, neoprene pond liner, or heavy grade tar paper) must initially extend at least 6" (152.4mm) in all directions around the perimeter of the enclosure and be trimmed closer to the enclosure.
- Contact local utilities or cable/piping locator services to ensure that the installation does not interfere with existing cables or piping.

2.2 Transportation and Lifting

A safe means of transportation to the site and a safe procedure for unloading the enclosure is necessary. At least two installation personnel are required to place the enclosures on the pad. Installation team must assess the transport path for all obstructions. An obstruction free path should be selected for transport. Use safe lifting practices. Electronic modules, batteries or other components must not be installed until the enclosure is securely set in place at its permanent location.

Enclosure	Approximate Shipping Weight
UPE-3	61 lb. (27.7kg)
UPE-6	75 lb. (34kg)



CAUTION!

- Never transport the unit with batteries installed. Batteries must ONLY be installed after the unit is transported to the site and secured to the pad. Transporting the unit with batteries installed may cause a short circuit, fire, explosion, and/or damage to the battery pack, enclosure and installed equipment. Damage caused by improper shipping or transporting a unit with batteries installed is not covered by the warranty.
- Enclosure must always remain in the upright position during the shipping, storage and installation process. Damage may result from enclosure being shipped or stored on its side.
- DO NOT lift the enclosure by the cover, unless empty.

2.0 Installation, continued

2.3 Enclosure Installation

Follow the procedure below for attaching the enclosure to a pedestal support or precast pad.

Tools and Materials Required:

- Ratchet set with 6" (152.4mm) extension.
- Vapor Barrier
- Utility Knife



CAUTION!

- A 25+ year continuous vapor barrier must be used between the enclosure and pad to prevent moisture ingress and possible corrosion caused by metal to concrete contact. The vapor barrier material (such as 30 lb. felt, neoprene pond liner, or heavy grade tar paper) should initially be extended at least 6" (152.4mm) in all directions around the perimeter of the enclosure and later be trimmed closer to the enclosure.

Procedure:

1. Unwrap the enclosure and inspect the contents. If items are missing or damaged, contact Alpha Technologies and the shipper immediately.
2. Place the vapor barrier material on the pad.
3. Unbolt the enclosure from the shipping pallet.
4. With no less than two installation personnel, lift the enclosure off the shipping pallet and place over the mounting studs on the pad.
5. Secure the enclosure to the pad using the hardware supplied with the precast pad or pedestal support.
6. Trim the vapor barrier material.

2.0 Installation, continued

2.4 Attaching the External Coax Raceway

The external coax raceway is held into place by two tabs at the bottom of the raceway that fit into slots at the bottom of the enclosure, and a wing nut at the top.

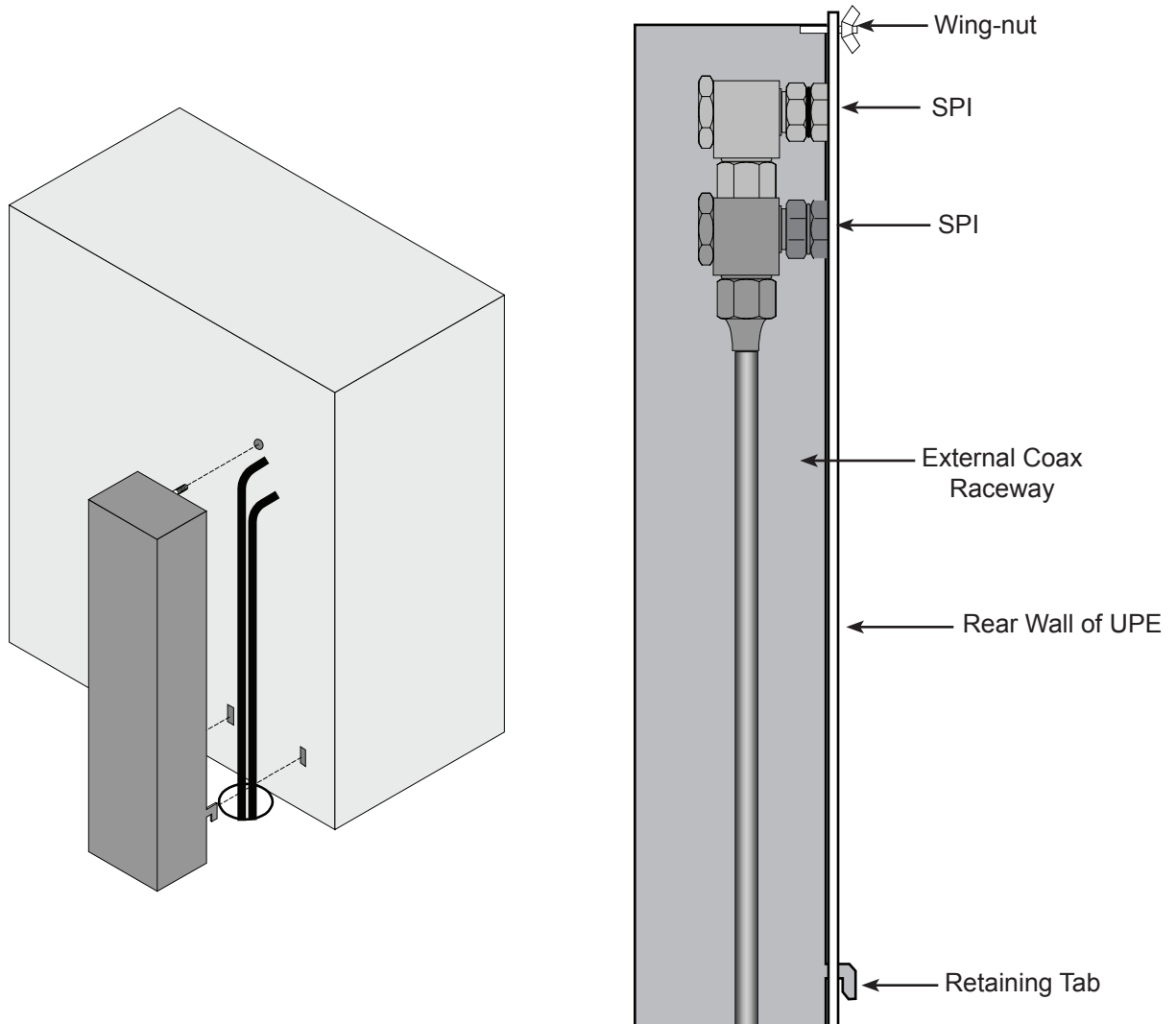

Fig. 2-1, External Coax Raceway

2.0 Installation, continued

2.5 Enclosure Grounding

Alpha recommends 5 ohm minimum ground resistance between enclosure and ground rods, in accordance with IEEE 1100-1999, Powering and Grounding Electronic Equipment.

Alpha Technologies assumes no responsibility or liability for failure of the installer to comply with the requirements of applicable local and national codes. Where allowed, exothermic welding may be used as an alternative to Burndy clamps and connectors.

ATTENTION:

Alpha Technologies recommends using the grounding method illustrated below. The grounding method for a particular site will be dependant upon soil type, available space, local codes, NEC (National Electric Code), and other site-specific characteristics.

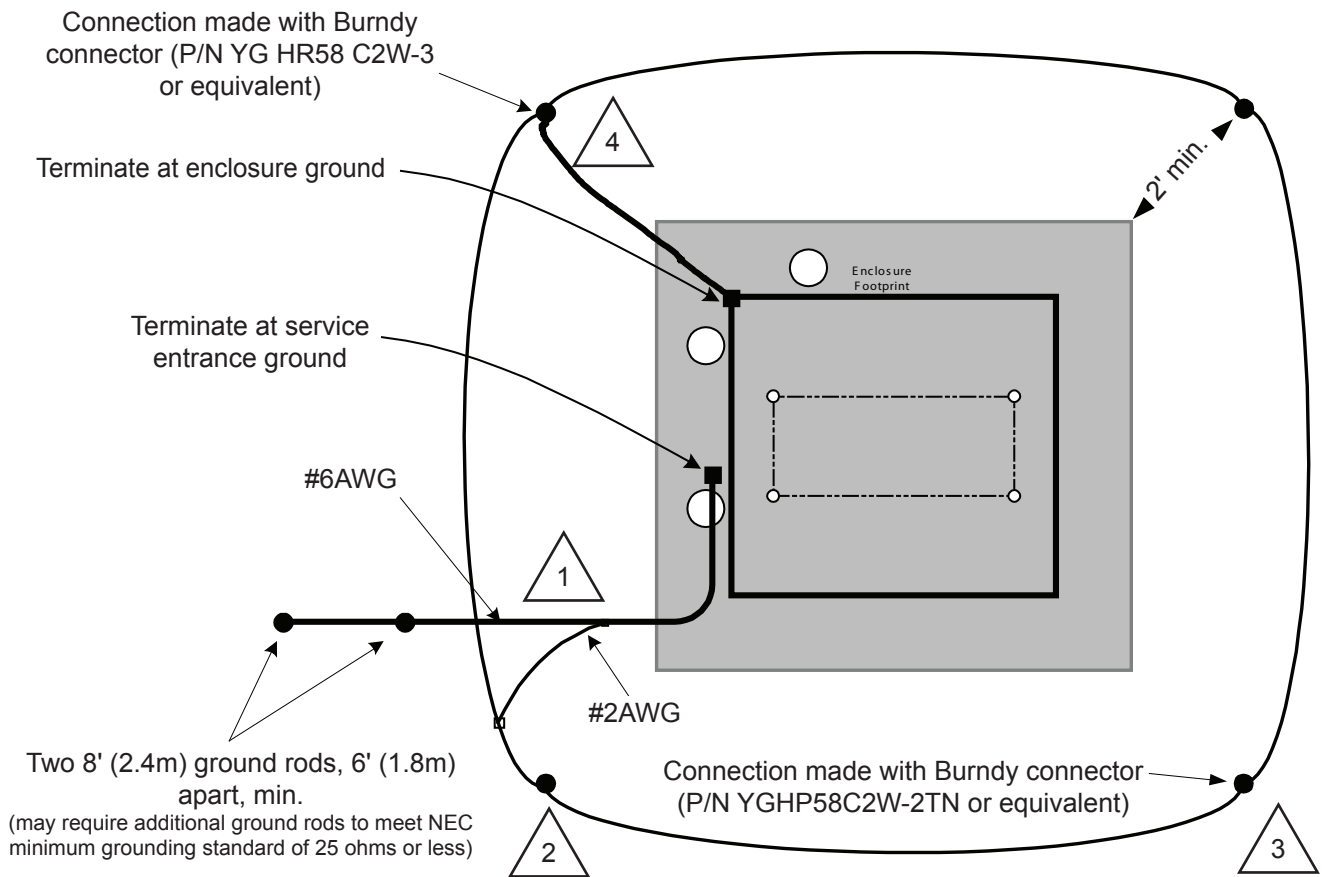

Service Grounding (required)



#6 bare copper wire from Service Neutral / Ground Bar with 2 ground rods located 6' (1.8m) apart.

Lightning Protection (optional)



1/2" x 8' (13mm x 2.4m) copper ground rod, four places, driven about 2' (0.6m) (typical) from the corners of the pad.



#6 bare copper wire loop terminated to each ground rod and buried below grade 30" (.762m) (min). Corrosion-proof connections (25+ year life-span), and hardware suitable for direct burial MUST be used.



#6 bare copper wire from loop to the enclosure.

2.0 Installation, continued

2.6 Utility Power Connection

Utility power enters the enclosure through the side or bottom of the UPE. The enclosure accepts a standard electrical fitting. The UPE Series can be equipped with an optional circuit breaker assembly located in the enclosure's module compartment.



CAUTION!

- Utility Power Connection procedure must ONLY be performed by qualified service personnel and in compliance with local electrical codes and common safety practices. Connection to utility power must be approved by the local utility before installing the power supply.



NOTICE:

A "high-magnetic" or HACR (Heating, Air Conditioning, Refrigeration) circuit breaker must be used in order to accommodate the high-inrush currents normally associated with the start-up of ferroresonant transformers (400A, no-trip, first-half cycle). Do not replace this circuit breaker with a conventional service entrance circuit breaker. Alpha recommends Square D circuit breakers ONLY because of increased reliability in this powering application.

Wiring From Duplex Receptacle to Service Disconnect:

In most cases, the following configurations qualify for service entrance use; however, other codes may apply. Always contact your local utility to verify that the wiring conforms to applicable codes.

240Vac Service (XM Series 2 915-240 Power Supply for UPE-3 and UPE-6):

Enclosures used with the XM Series 2 915-240 is equipped with one or two 240Vac duplex receptacles to provide power to the power supply and peripheral equipment. The receptacle, NEMA 6-15R, is protected by a single, 2-pole, common trip 15A circuit breaker located inside the service entrance. Wiring is typically 14AWG per NEC code, a grounding clamp, located on the enclosure, facilitates dedicated grounding.

120Vac 20A Service (XM Series 2 915-120 Power Supply):

Enclosures used with the XM Series 2 915-120 are equipped with one or two 120Vac duplex receptacles to provide power to the power supply and peripheral equipment. The receptacle, NEMA 5-20R, is protected by a single pole 20A circuit breaker located inside the service entrance. Wiring is typically 12AWG per NEC code, a grounding clamp, located on the enclosure, facilitates dedicated grounding.

120Vac 15A Service (XM Series 2 615):

Enclosures used with the XM Series 2 615 are equipped with one or two 120Vac duplex receptacle to provide power to the power supply and peripheral equipment. The receptacle, NEMA 5-15R, is protected by a single-pole, 15A High Magnetic circuit breaker located inside the service entrance. Wiring is typically 14AWG per NEC code, a grounding clamp, located on the enclosure, facilitates dedicated grounding.



NOTICE:

Alpha recommends wiring with 12AWG to accommodate upgrade from 240Vac 15A to 120Vac 20A.

2.0 Installation, continued

2.6 Utility Power Connection, continued

The UPE Series enclosures may be configured with the following service options. Please contact your Alpha Technologies representative for assistance selecting the configuration that best suits your requirements.

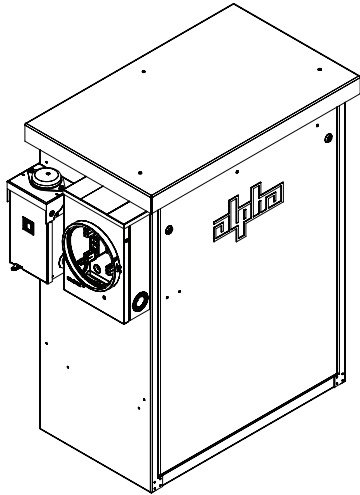

Standard Meter Base/BBX (UMB)

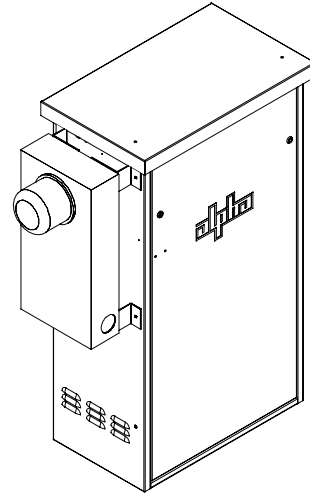

EUSERC Meter Base (EMB)
(UPE-6 Only)

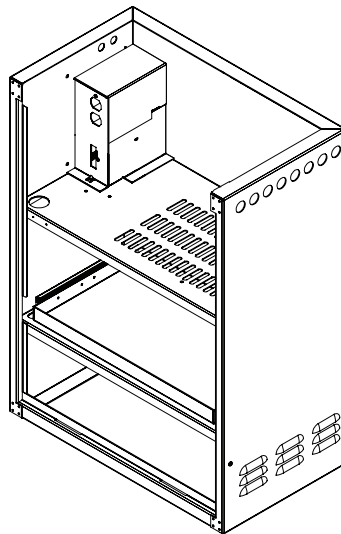

Internal Service Entrance (ISE)

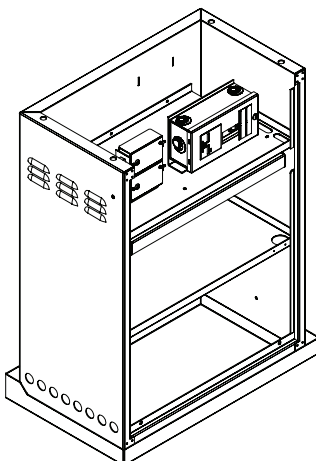

Bottom Mount BBX/SPI (IBBX-BM)
(enclosure is upside down)

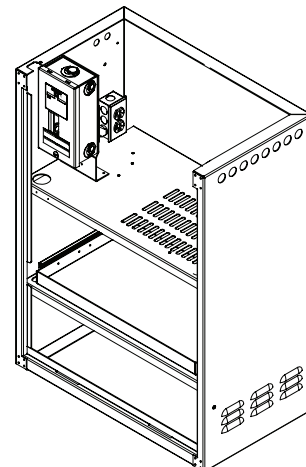

Internal BBX (IBBX-TM)

2.0 Installation, continued

2.6 Utility Power Connection, continued

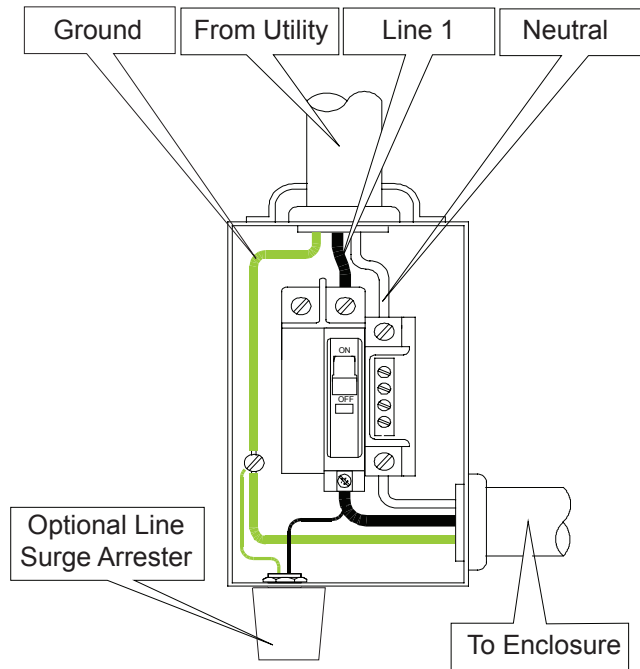

120Vac Service Entrance

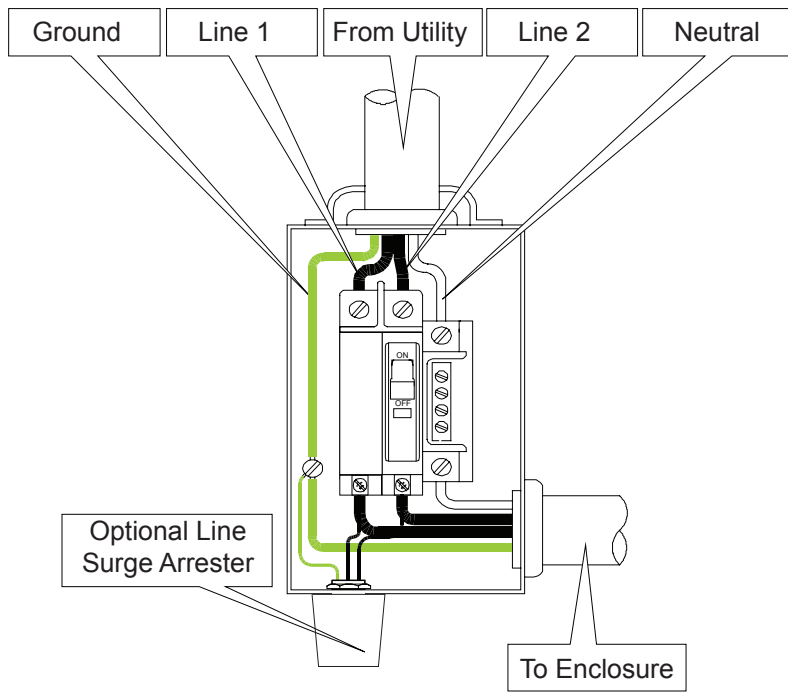

240 Vac Service Entrance

Fig. 2-2, Typical Service Entrance Wiring

2.0 Installation, continued

2.6 Utility Power Connection, continued

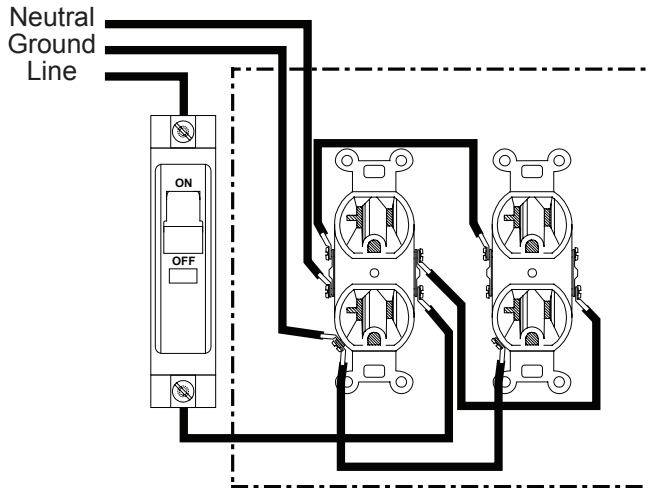

BQO, 120Vac, 20A Circuit

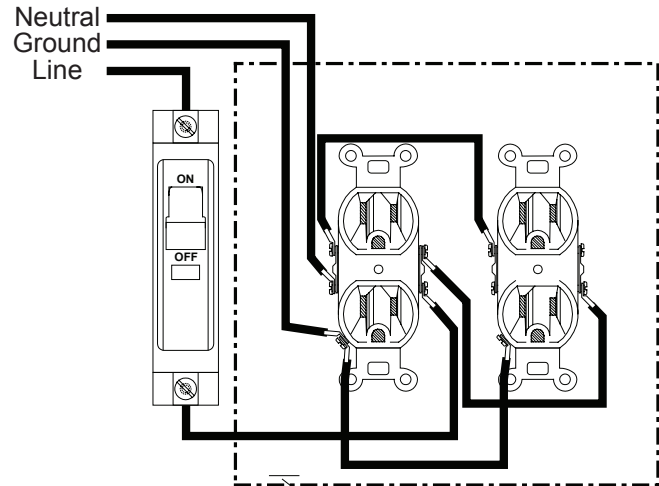

BQO, 120Vac, 15A Circuit

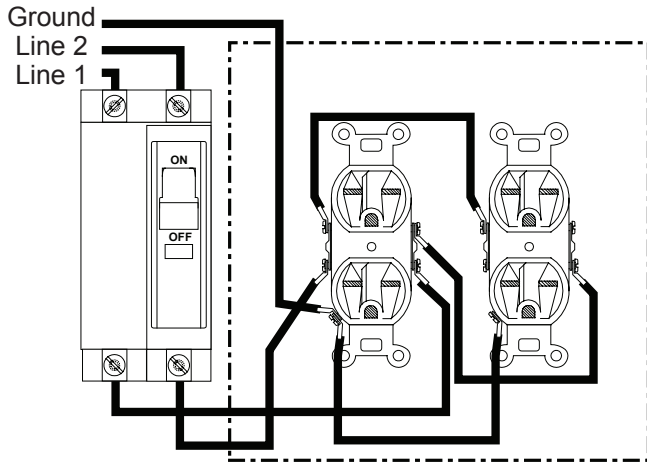

BQO, 240Vac, 15A Circuit

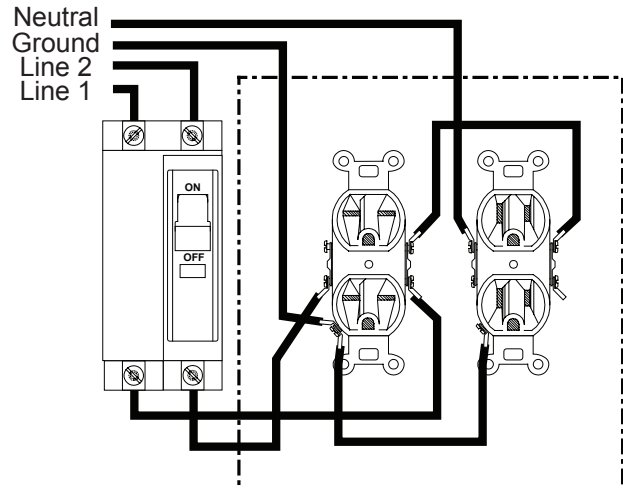

BQO, 120/240Vac, 15A Circuit

Circuit Breaker Part Numbers		
Circuit Description	Alpha Part Number	Square D part Number
240V Installation - HACR (15A)	470-224-10	Q0215
120V Installation - HM (20A)	470-017-10	Q0120HM
120V Installation - HM (15A)	470-013-10	Q0115HM
BBX - External Service Disconnect 70 Amp	020-085-10	Q02-4L70RB
BBX - External Service Dicsonnect 100 Amp	020-141-10	Q08-16L100RB

Fig. 2-3, Breaker-Quad-Option Wiring and Circuit Breaker Part Numbers

2.0 Installation, continued

2.6 Utility Power Connection, continued

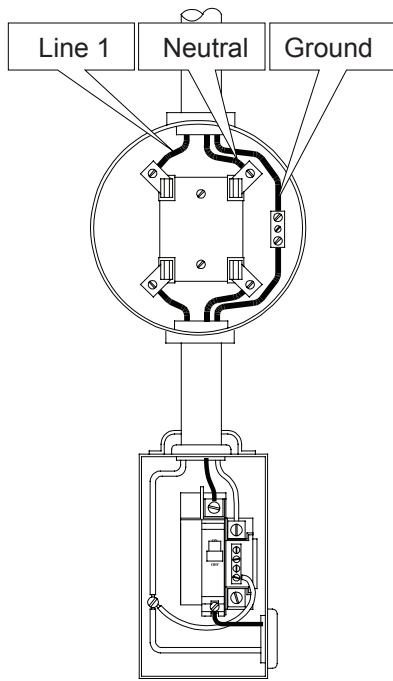

120Vac Meter Base

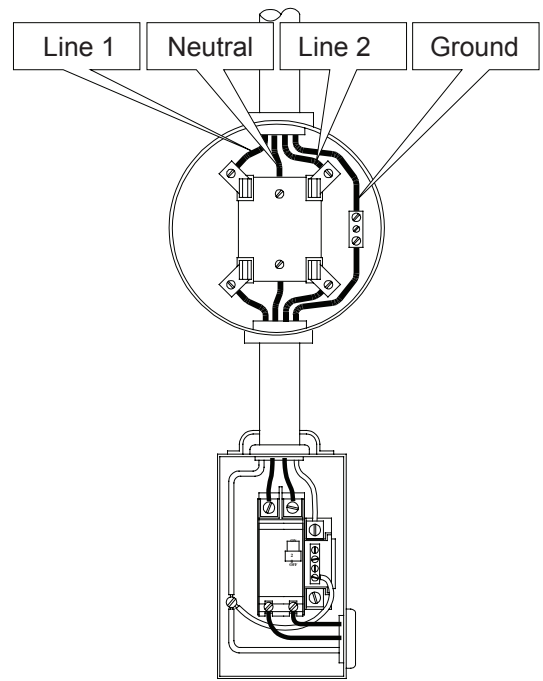

240Vac Meter Base

Fig. 2-4, 120/240Vac UL Wiring



CAUTION!

Neutral should be bonded to ground in PRIMARY service entrance only.

2.0 Installation, continued

2.7 Coaxial Cable Connection

1. Do NOT remove SPI cover until all sources of power have been removed. Verify the SPI is not connected to power supply.
2. Remove the two screws holding the cover onto the SPI's chassis.
3. Remove the SPI cover, exposing the circuit board and seizure screw assembly.

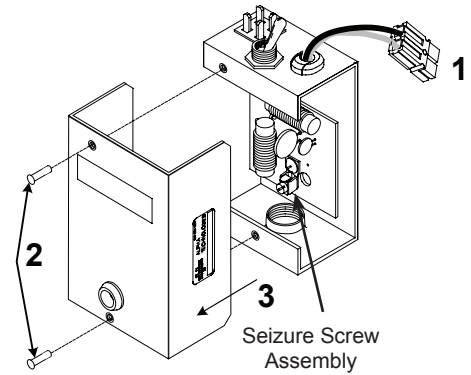

WARNING! ELECTRICAL HAZARD

Verify there is no power to the SPI before removing the outer cover. Failure to do so may expose the technician to hazardous voltages.

4. Insert the coaxial termination into the output port on the bottom of the SPI and tighten snug.

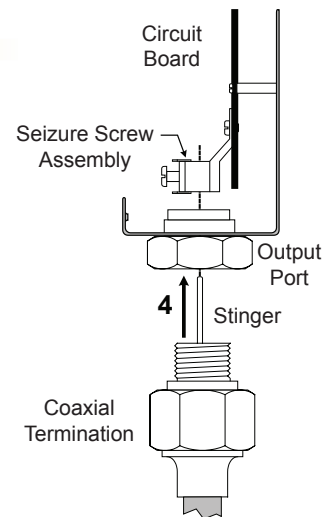

5. Tighten the seizure screw to 35 in-lbs (4 Nm).

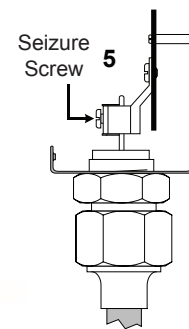

CAUTION!

To prevent arcing, and failure of the unit, the center conductor (stinger) of the coaxial termination must go fully inside the seizure screw assembly.

6. Replace the SPI's cover and reinstall the screws.
7. Verify the switch on the top of the SPI is in the ON position.

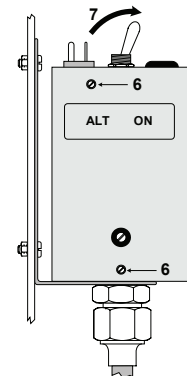

2.0 Installation, continued

2.8 Power Supply Placement

Place the power supply on the top shelf over the vent louvers on the right. Do not connect any cables or connectors to the power supply at this time.

2.9 Battery Installation

WARNING! ELECTRICAL HAZARD

Battery systems represent a risk of electrical shock and high short-circuit currents. The following precautions must be observed when maintaining batteries:

- Remove all personal metal objects (watches, rings, etc.)
- Use insulated tools
- Wear eye protection and rubber gloves
- Observe circuit polarities
- Do not make or break live circuits
- Do not lay metal tools and hardware on top of the batteries

2.9.1 Battery Date Code Usage and Identification

Every battery contains a DATE CODE. This code is usually located near the positive (+) terminal, and must be recorded in the maintenance log. If you use batteries other than those installed by Alpha, consult the batteries' manufacturer's documentation for date code type and placement.

NOTICE:

The date code scheme and location varies depending on the age of the battery used.

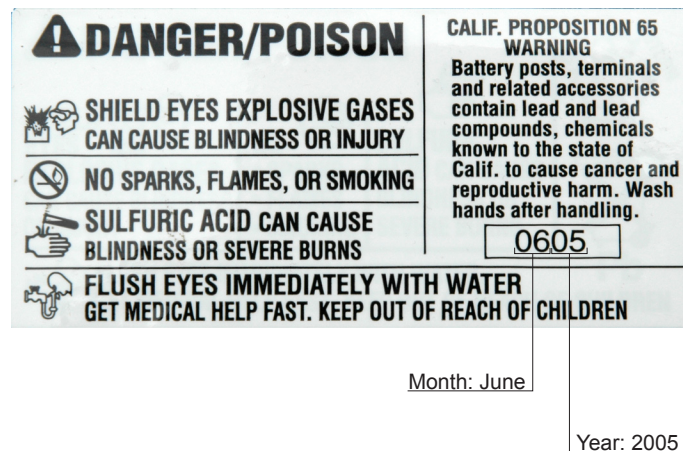

Fig. 2-5, Battery Date Code

2.0 Installation, continued

2.9 Battery Installation, continued

2.9.2 Battery Installation Procedure

WARNING! ELECTRICAL HAZARD

To prevent arcing, never allow live battery cables to make contact with the enclosure. Disconnect battery leads, or wrap the cable lugs with electrical tape.

CAUTION!

Threaded insert terminals require the use of 3/4" (19mm) bolts. The use of 1" (25.4mm) bolts will seriously damage the battery. The only exception is the terminal with the large spacer for the in-line fuse link. See Section 2.9.3 for details.

NOTICE:

In battery configurations made up of multiple battery strings, Alpha recommends the use of in-line fuses.

Procedure:

1. Place the batteries on the enclosure's battery slide tray or battery shelf. The correct arrangement of the batteries on the tray or shelves varies between enclosure models. See Figs. 2-8 and 2-9 for the correct battery arrangement. Leave a minimum of one inch of ventilation space between the batteries.
2. To make identification and record keeping easier, number and label the batteries. Record each battery's number and date code in the power supply maintenance log.
3. Using the battery arrangement diagrams as a reference, connect the batteries in series to achieve 36Vdc. Refer to the diagrams for the location of the optional in-line fuses. For AlphaCell batteries, torque terminal connections to approximately 65 in-lbs (7.3 Nm) at installation and re-torque to 50 in-lbs (5.6 Nm) during routine maintenance. For non-Alpha batteries, torque to manufacturer's specifications.
4. Verify the batteries are properly connected by checking the polarity and voltage of the battery cable connector with a digital voltage meter. DO NOT connect the battery string or strings to the power supply at this time.
5. The power supply battery charger collects battery temperature compensation information with a Remote Temperature Sensor (RTS) attached to one of the batteries. Refer to the Fig. 2-7 or Fig. 2-8 to determine the RTS attachment point. See Section 3.1 for RTS the attachment procedure.
6. Route the battery cable connector into the power supply compartment. DO NOT connect to the batteries to the power supply at this time.

CAUTION!

Recheck the polarity and voltage of the battery cable connector before proceeding. Connecting the battery string or strings to the power supply with incorrect polarity will cause a short circuit and possible equipment damage.

2.0 Installation, continued

2.9 Battery Installation, continued

2.9.3 Battery Terminal Connections

NOTICE:

- Various types of batteries with different mounting styles and hardware may be shipped with the system. ALWAYS refer to the battery manufacturer's specifications for correct mounting hardware and torque requirements. Use only the hardware and torque recommended by the battery manufacturer.
- There are two types of battery terminals: the newer, threaded insert terminals, and the older, flag terminals. The following drawings and pictures are for illustrative purposes only.

Threaded Insert Terminals

CAUTION!

Threaded insert terminals require the use of 3/4" (19mm) bolts. The use of 1" (25.4mm) bolts will seriously damage the battery. The only exception is the terminal with the large spacer for the in-line fuse link.

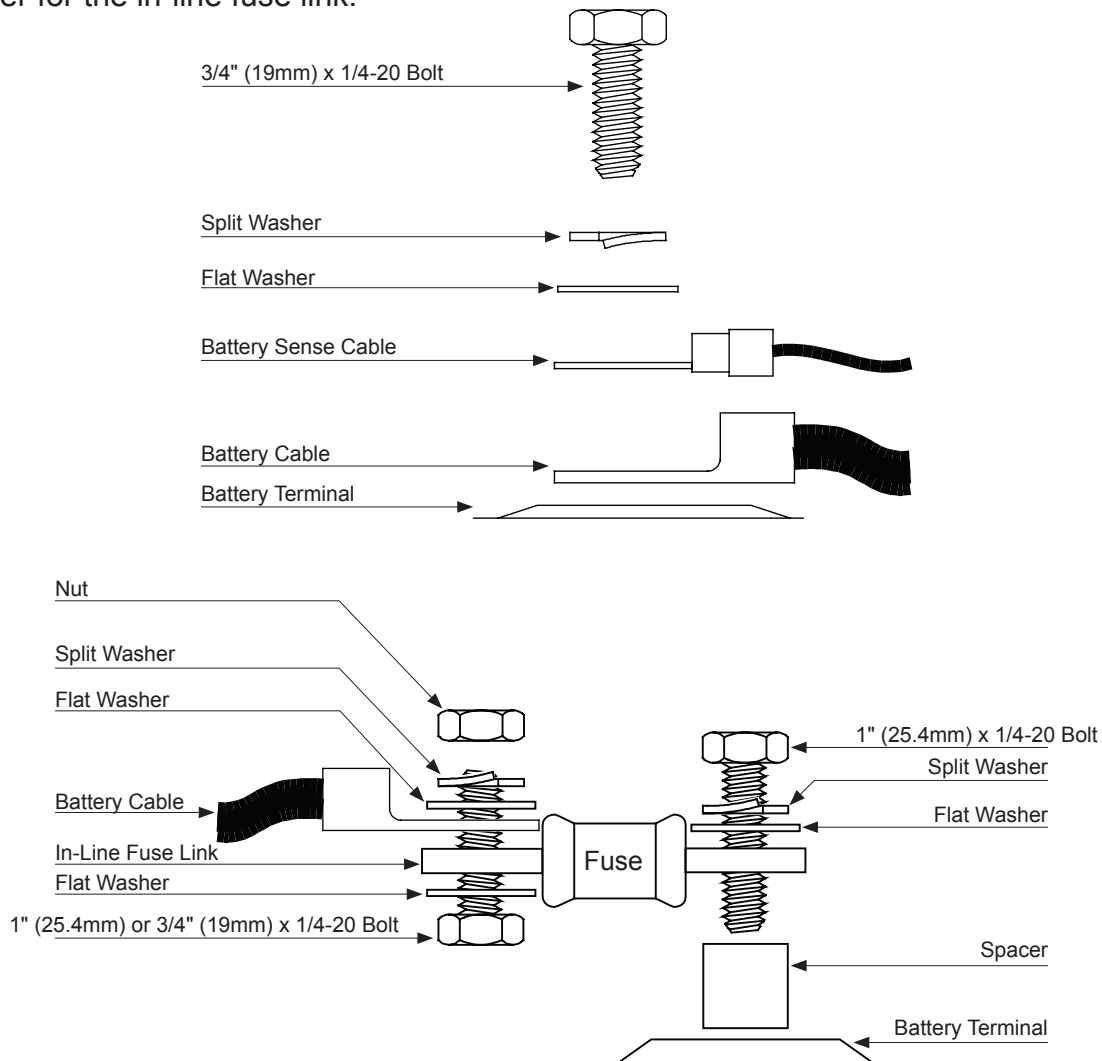

Fig. 2-6 Threaded Insert Battery Terminal Connections

2.0 Installation, continued

2.9 Battery Installation, continued

2.9.3 Battery Terminal Connections, continued

Flag Terminals

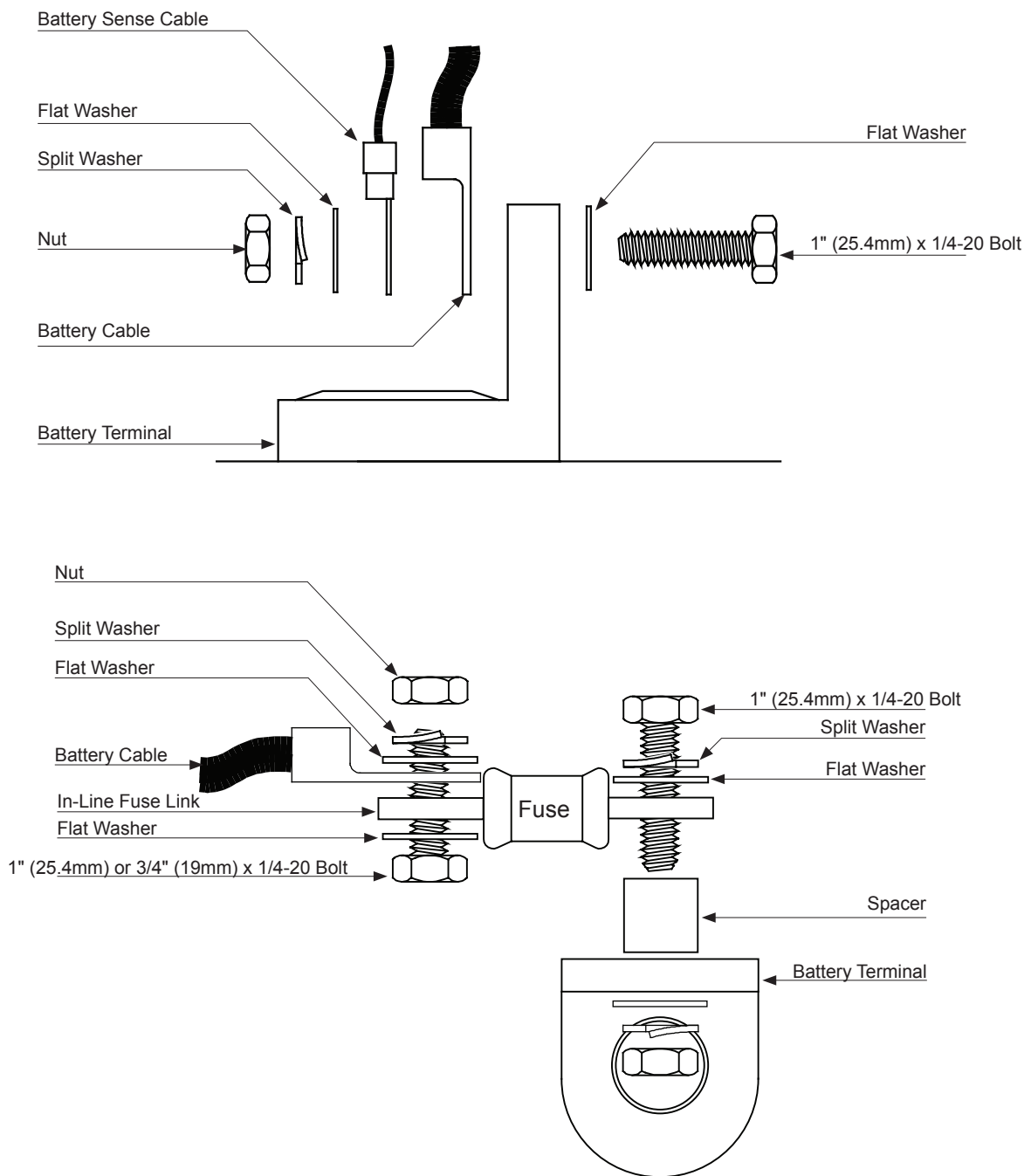

Fig. 2-7, Flag Battery Terminal Connections

2.0 Installation, continued

2.9 Battery Installation, continued

2.9.4 Connecting the Battery Integration Tray

Connect the battery cable kit (Alpha P/N 875-690-20) to each battery, and to matching Anderson connector on the Battery Integration Tray (BIT). Torque to the battery manufacturer's specification (for AlphaCell batteries see battery label).

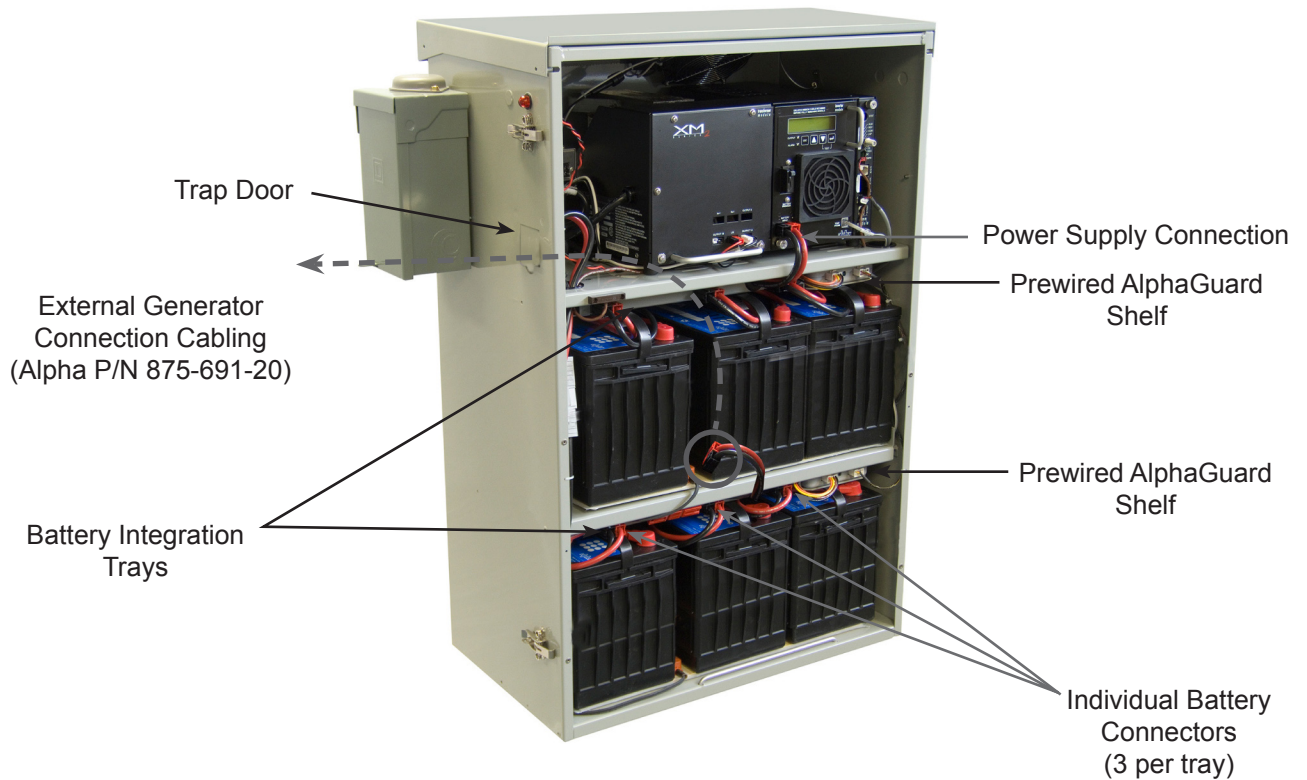

2-8, Battery Integration Tray Connections

2.0 Installation, continued

2.9 Battery Installation, continued

2.9.5 Battery Wiring Diagrams (UPE with Slide Tray)

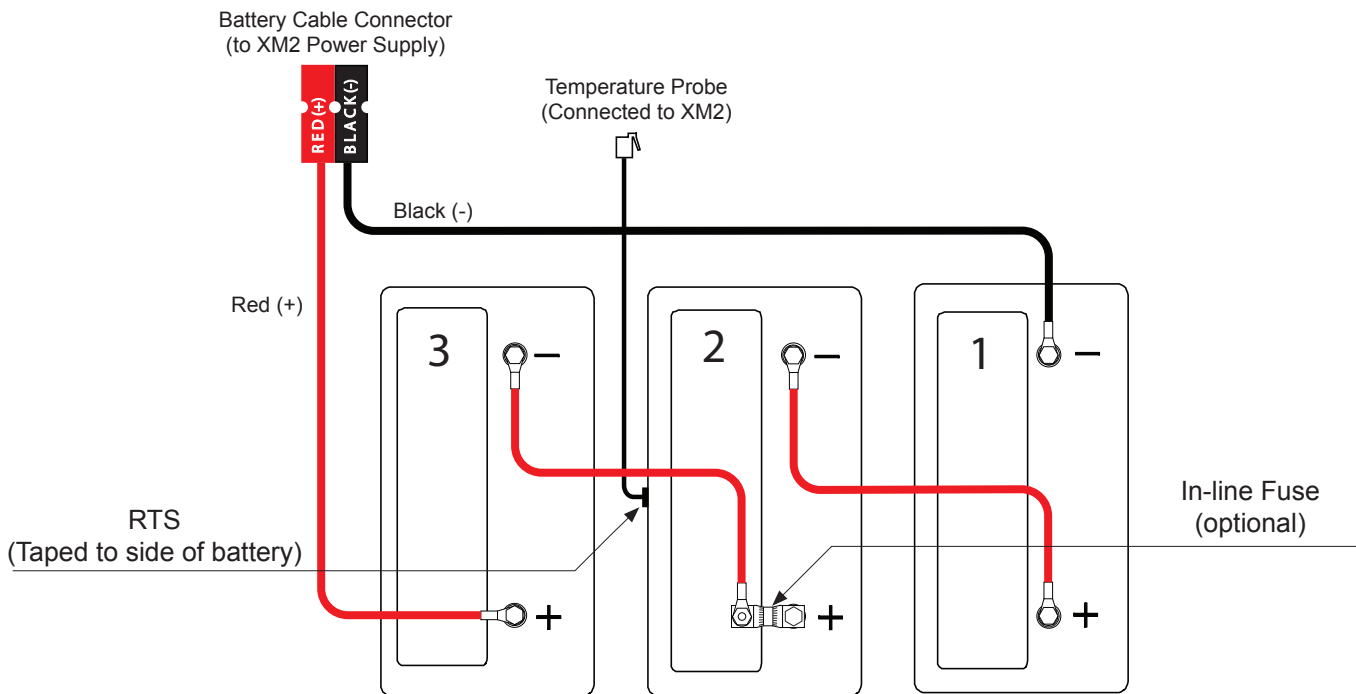

Fig. 2-9, UPE-3 Battery Wiring Diagram (for use with slide tray)

2.0 Installation, continued

2.9 Battery Installation, continued

2.9.5 Battery Wiring Diagrams (UPE with Slide Tray), continued

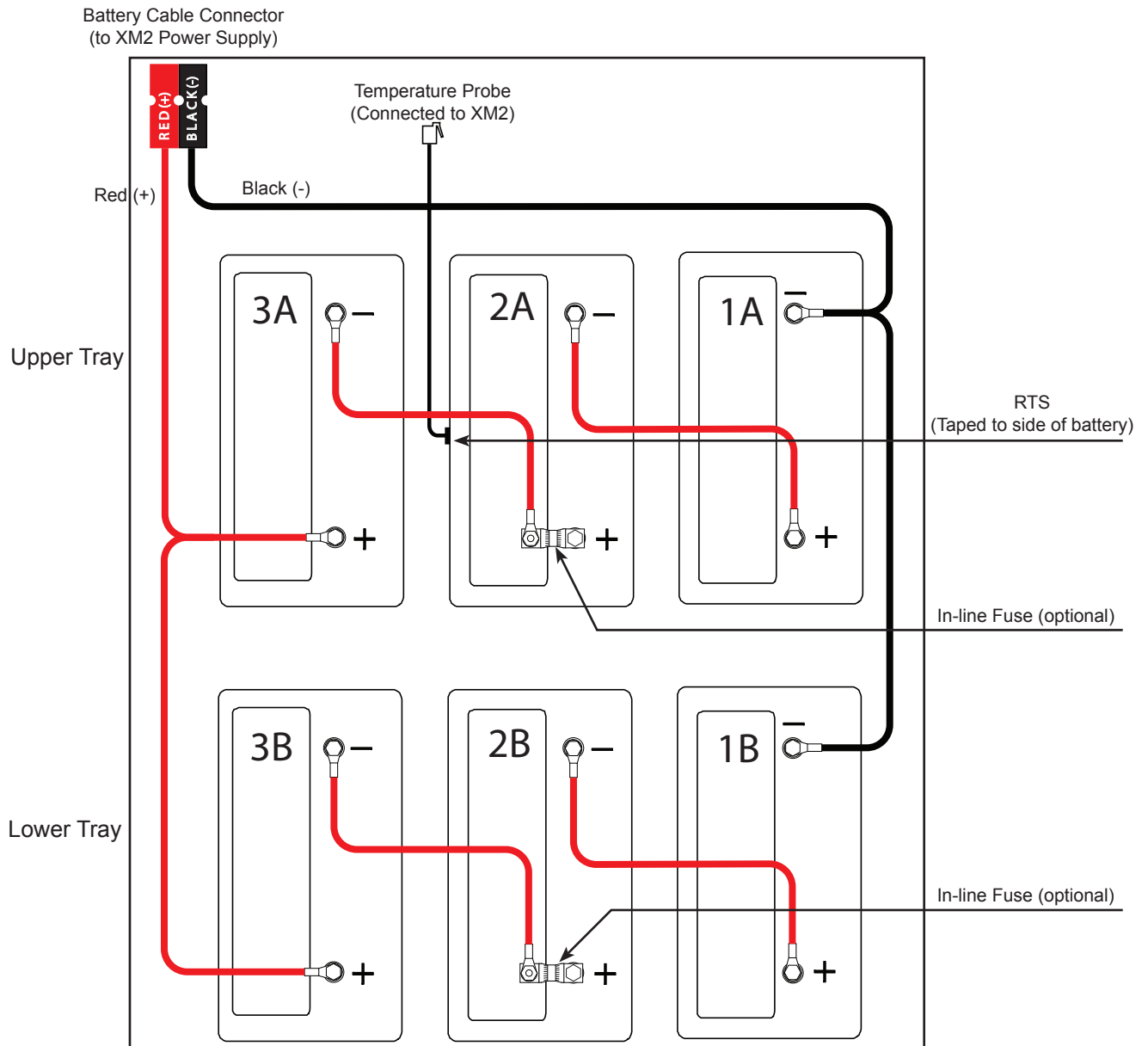

Fig. 2-10, UPE-6 Battery Wiring Diagram (for use with slide tray)

2.0 Installation, continued

2.10 Enclosure Protection

Alpha Technologies cannot anticipate all of the ways a vehicle may potentially threaten an installed system, or the specific type of protection that is appropriate for a particular location. The determination of the threat to the equipment and the means of protection are the responsibility of the end user of the equipment. The following installation drawing is a general recommendation and not intended to be a specific guideline for protecting the equipment. The numbers of bollard posts (or other protection devices) depend upon equipment locations, site surveys, traffic patterns and local codes. Do not install enclosure within 10' (3m) of a water sprinkler to prevent water from entering enclosure.

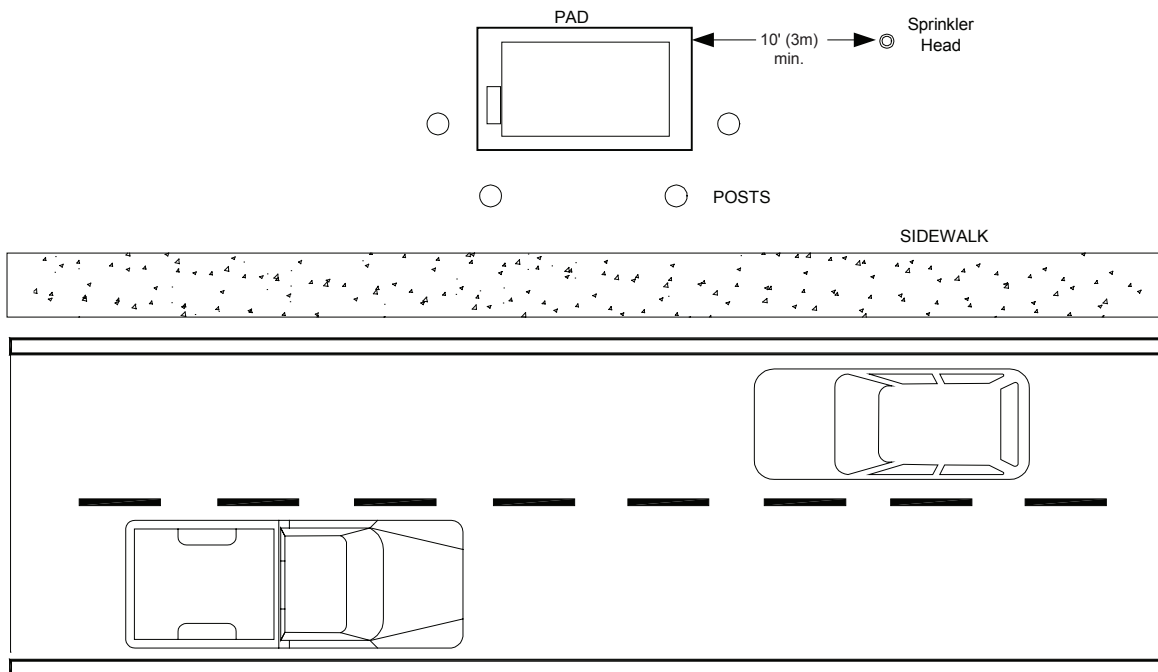

Fig. 2-11, Bollard Placement

3.0 Enclosure Options

3.1 Battery Remote Temperature Sensor (RTS)

Procedure:

1. Attach the RTS probe to the inner side of battery 2A with adhesive tape.
2. The other side of the RTS probe is attached to the front panel of the XM2 power supply, in the jack labeled TEMP PROBE.



CAUTION!

For enclosures with multiple battery strings, the Remote Temp Sensor (RTS) must be located with the warmest (normally the topmost) battery string. This ensures proper operation of the battery charger's temperature compensation circuit. Failure to locate the RTS with the warmest battery string could result in overcharging and premature battery failure.



Fig. 3-1, RTS Placement

3.0 Enclosure Options, continued

3.2 Lightning and Surge Arrester Options

Alpha's LA Series voltage suppressors provide reliable protection of power supplies and related equipment from the damaging power line disturbances common to cable TV and broadband applications. The LA Series incorporates Metal Oxide Varistor (MOV) technology that effectively limits voltage surges and absorb excessive energy levels. Housed in a durable polymer casings with standard electrical plugs, the LA Series plugs directly into any electrical outlet.

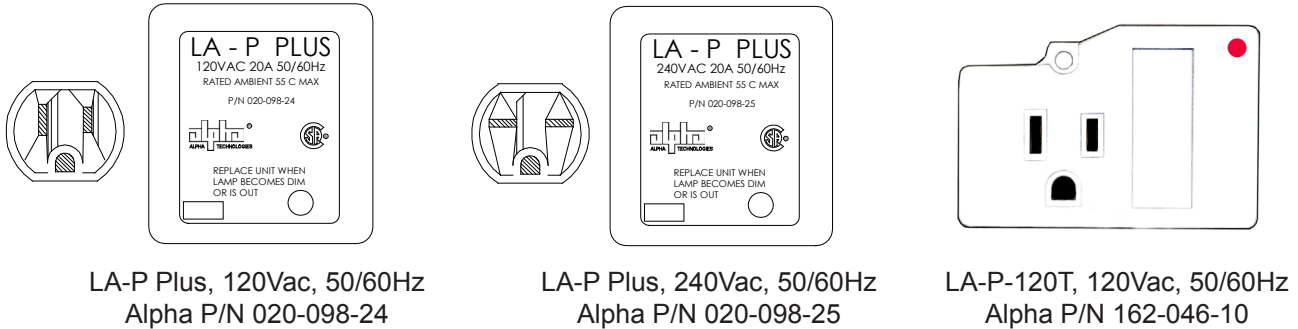

Fig. 3-2, LA-P Plus

The ISA-120/240 Secondary Surge Arrester (Alpha P/N 062-041-10) is hard-wired and protects electrical equipment and wiring against lightning induced surges. The arrester diverts lightning surges to ground, and is designed to handle repetitive operations. Severe lightning can cause the device to fail, and it should be replaced if either of the LEDs fails to light.



Fig. 3-3, ISA-120/240 Secondary Surge Arrester

3.0 Enclosure Options, continued

3.3 Battery Heater Mat

Battery heater mats are designed to increase battery capacity in cold environments. The thermostat is factory set to turn the mat on at 40°F (4.44°C), and off as the temp rises above 50°F (10°C). As a safety feature, the mat has a thermal fuse that opens at 180°F (82.22°C) to protect the batteries from overheating. To install the mats:

1. Remove the batteries from the tray(s).
2. Place the heater mat in the bottom of the tray(s).
3. Replace the batteries.
4. Plug the AC line cord into the closest receptacle.

3.4 LRI-ACI Lamp Option

LRI Option

The LRI lamp (red lamp) is located on the outside, on either the right or left side of the enclosure. The lamp comes ON only when the power supply is running on backup power (STANDBY). During normal AC line operation, the lamp remains OFF. Whenever a fault is detected, the lamp flashes to indicate that service is required. The LRI can be used as a simple form of status monitoring by allowing cable technicians to check the operational status of the power supply without having to open the enclosure. Connect the LRI lamp to the jack on the front of the power supply labeled LRI.

ACI Option

The AC indicator (green lamp) is located on the outside, on either the right or left of the enclosure. When the lamp is ON, it indicates AC power is available at the power supply output (normal operation). This allows a cable technician to drive by and determine the status of the power supply without having to open the enclosure. Connect one connector of the ACI lamp to the OUTPUT 1 jack on the front of the power supply, and the other to the SPI.

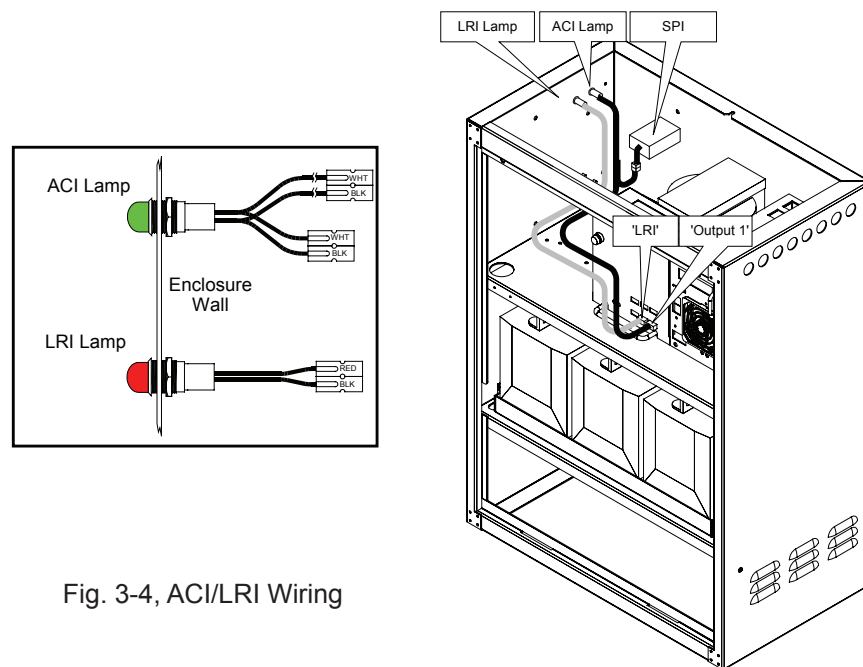

Fig. 3-4, ACI/LRI Wiring

3.0 Enclosure Options, continued

3.5 Enclosure Door Tamper Switch and Cooling Fan Options

Tamper Switch

The Tamper Switch is located on the edge of the power supply shelf, opposite the power supply. The switches are available in Normally Closed (Alpha P/N 740-216-21) and Normally Open (Alpha P/N 740-216-26). The USM2, USM-2.5, or DSM options are required to monitor the Tamper Switch. The connector attached to the sensor portion of the switch must be connected to the TMPR connection on the USM or DSM card.

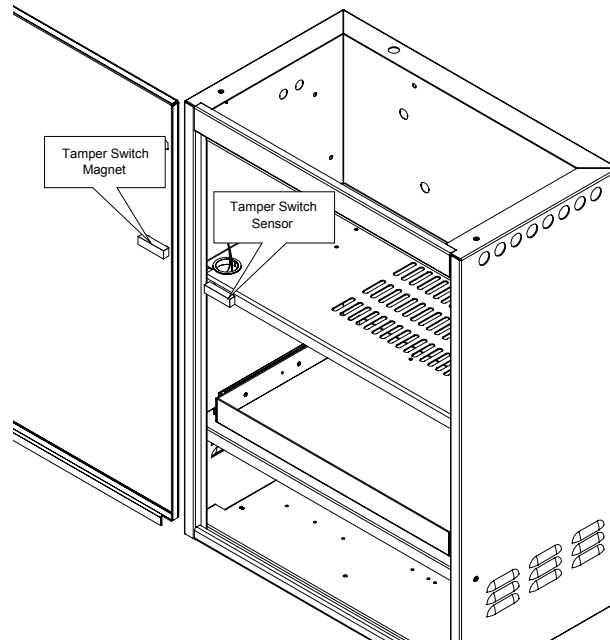

Fig. 3-5, Tamper Switch Placement

Enclosure Cooling Fan

An optional Cooling Fan Kit (Alpha P/N 745-101-22) is available for the UPE-3 and UPE-6. The fan is thermostatically controlled and powered by the XM Series 2 power supply.

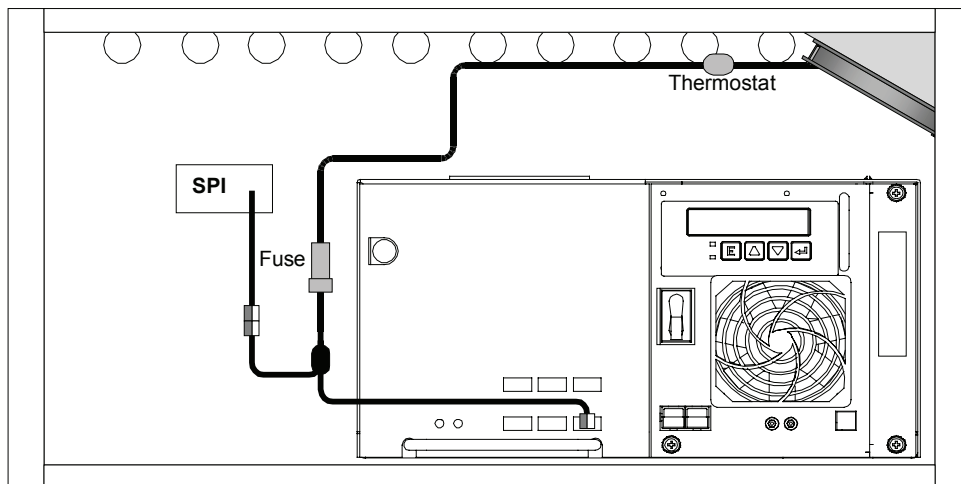

Fig. 3-6, Cooling Fan Placement

Power

Alpha Technologies 

Alpha Technologies
3767 Alpha Way
Bellingham, WA 98226
USA
Tel: +1 360 647 2360
Fax: +1 360 671 4936
Web: www.alpha.com

Alpha Technologies Ltd.
4084 McConnell Court
Burnaby, BC, V5A 3N7
CANADA
Tel: +1 604 430 1476
Fax: +1 604 430 8908

Alpha Technologies
Europe Ltd.
Twyford House Thorley
Bishop's Stortford
Hertfordshire CM22 7PA
UNITED KINGDOM
Tel: +44 0 1279 501110
Fax: +44 1 279 659870

Alpha Technologies GmbH
Hansastraße 8
D 91126 Schwabach
GERMANY
Tel: +49 9122 79889 0
Fax: +49 9122 79889 21

Alphatec, Ltd
339 St. Andrews Street
Suite 101 Andrea Chambers
3307 Limassol
CYPRUS
Tel: +357 25 375675
Fax: +357 25 359595

AlphaTEK ooo
Khokhlovskiy Pereulok 16
Stroenie 1 Office 403
109028 Moscow
RUSSIA
Tel: +7 495 916 1854
Fax: +7 495 916 1349

Alphatec Baltic
S. Konarskio Street G.49-201
Vilnius LT-03123
LITHUANIA
Tel: +370 5 210 5291
Fax: +370 5 210 5292

Alpha Technologies
34, Grande Rue
Bétheny, F-51450
France
Phone: +33 32 64990 54
Fax: +33 67 54289 44